

Introduction to Unigraphics CAD/CAE/CAM System

Computer Aided Design



University of Victoria

Integrated CAD/CAE/CAM Systems

- **Professional CAD/CAE/CAM Tools**

- Unigraphics NX (Electronic Data Systems Corp - EDS)
- CATIA (Dassault Systems - IBM)
- Pro/ENGINEER (PTC)
- I-DEAS (EDS)

- **Other CAD and Graphics Packages**

- AutoCAD Mechanical Desktop / Inventor
- SolidWorks (Dassault Systems - CATIA)
- Solid Edge (EDS – UG NX)
- MicroStation
- Intergraph

Unigraphics NX

- A full spectrum design modeling, analysis, simulation and manufacturing CAD/CAE/CAM software from Unigraphics Solutions
- One of the older and well-established CAD/CAE/CAM system.
- A software of choice for a wide variety of applications, especially in automotive and aerospace product development.



Unigraphics NX



Automotive & Aerospace Virtual Product Development Process

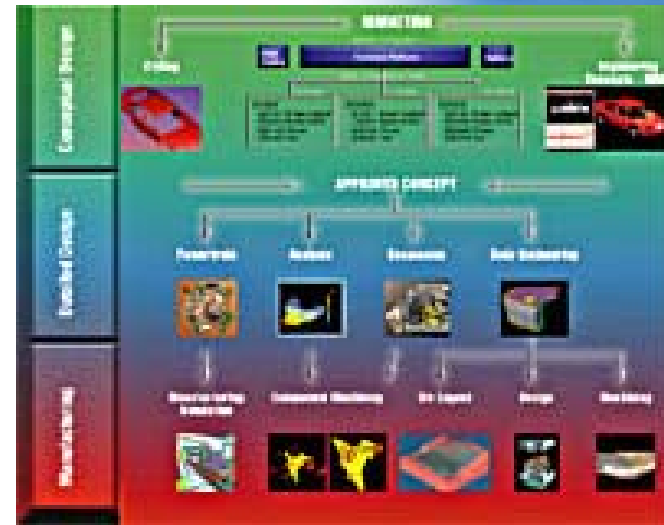

Solid Edge

- SolidWorks equivalent to UG NX
- Powerful modeling tools
- Integrated design management
- Productivity for large assemblies
- Ease of adoption
- Model faster
- Eliminate errors with engineering aids
- Drafting tools
- Unmatched interoperability
- Design-through-manufacturing

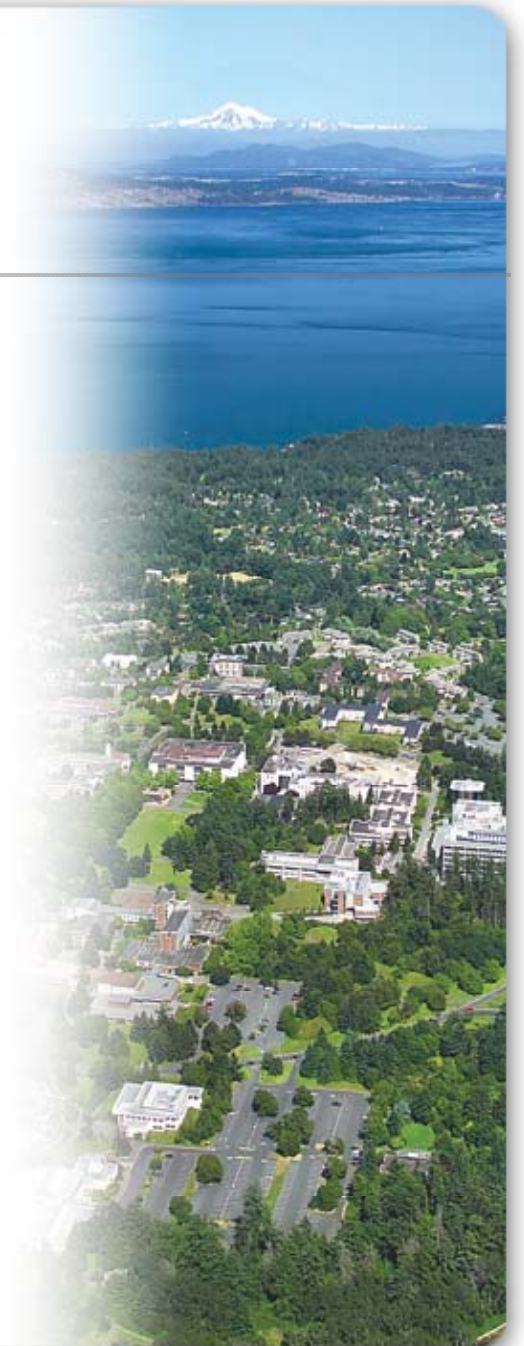

PACE - Partners for the Advancement of CAD/CAM/CAE Education

- To integrate 3-D solid modeling and other parametrics-based CAD/CAM/CAE applications (Unigraphics-related) into the curricula of strategically selected academic institutions worldwide (1999-)
- Participating Industry
 - General Motors Corp.,
 - Sun Microsystems, and
 - EDS
- Donations
 - computer-aided design, manufacturing, and engineering software
 - ~ Unigraphics, IDEAS, SolidEdge
 - hardware (Sun workstations) and
 - training to universities
 - automotive parts, and
 - collaborative industry projects for students.

EcoCAR HEV Design and Analysis Using Unigraphics NX

Integrating the GM 2-Mode Transmission into the EcoCAR

Design Team: David Robinson, Degnan Hembroff and Michael Versteeg

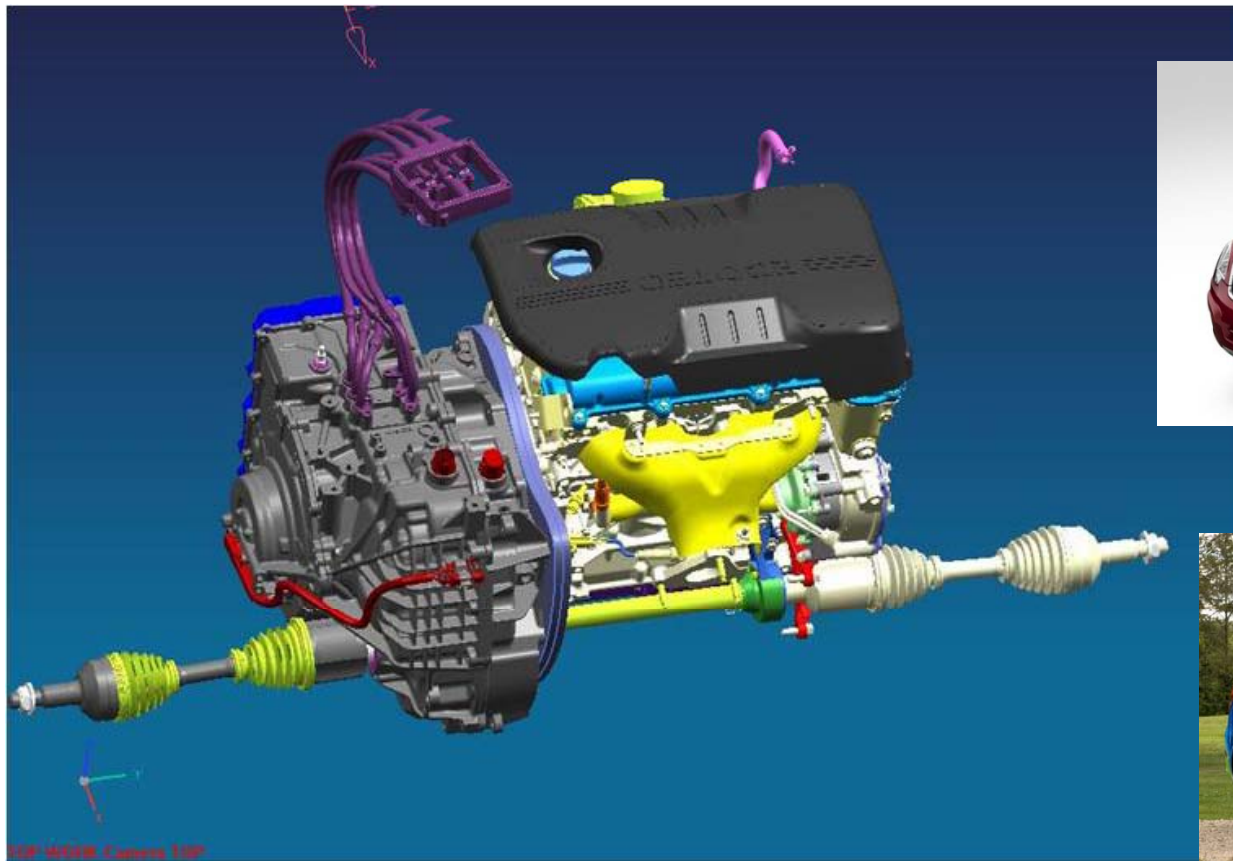

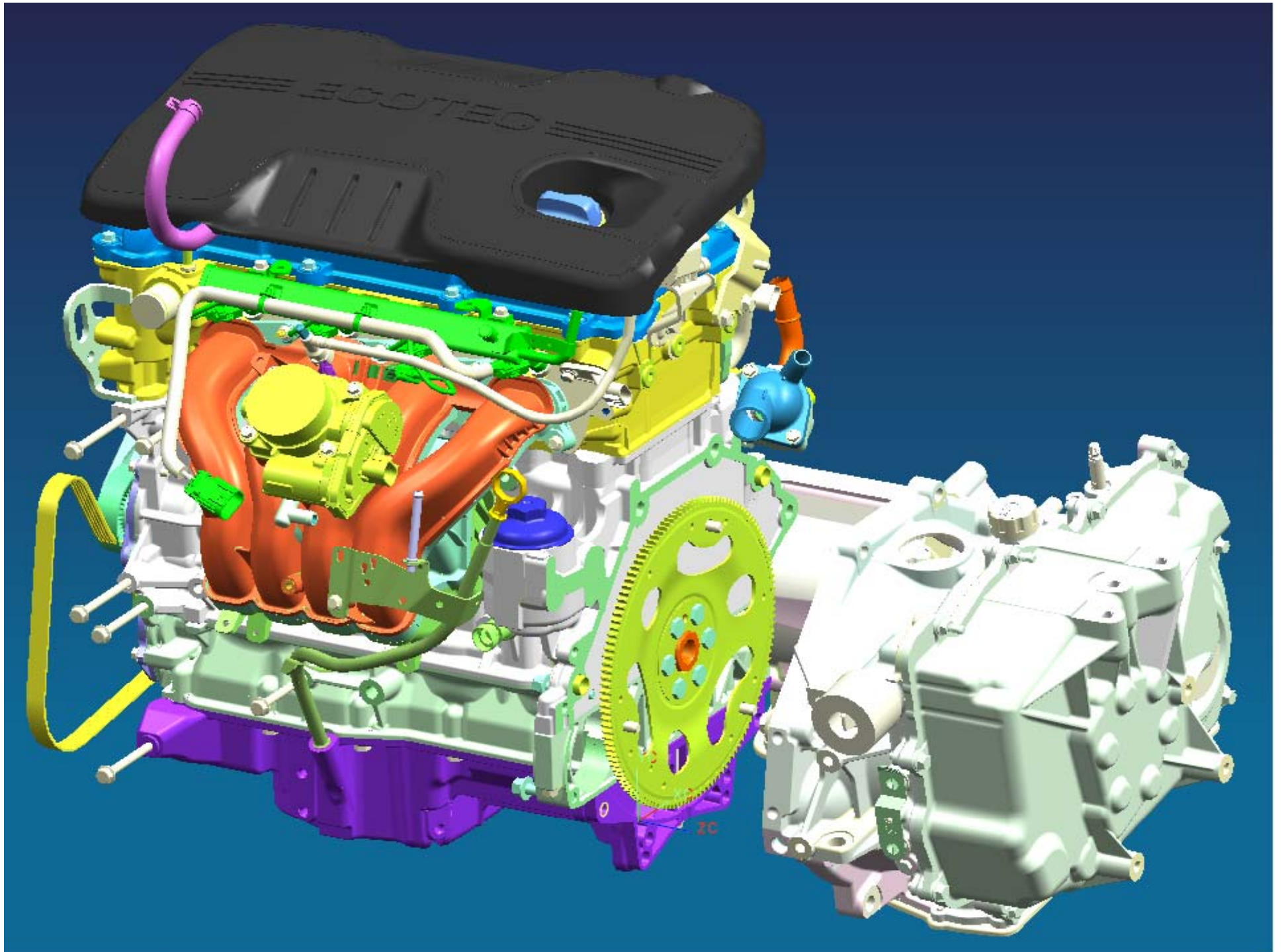

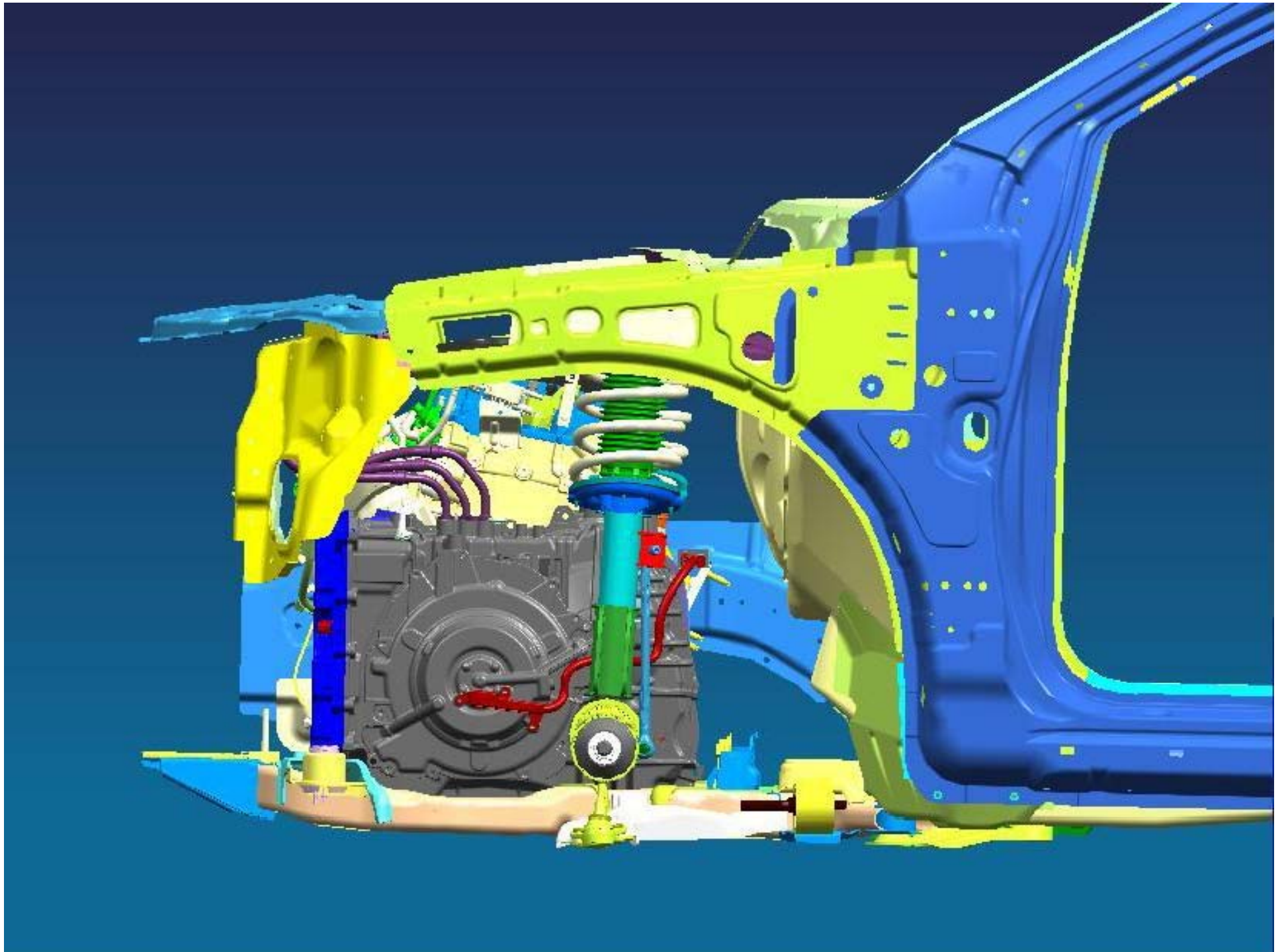

EcoCAR HEV Design and Analysis Using Unigraphics NX

2-Mode AWD Plug-in Hybrid Vehicle Battery Pack Design

Electrical Team: Jonathan Cronk, Dian Ross, & Mechanical Team: Ian Loughheed

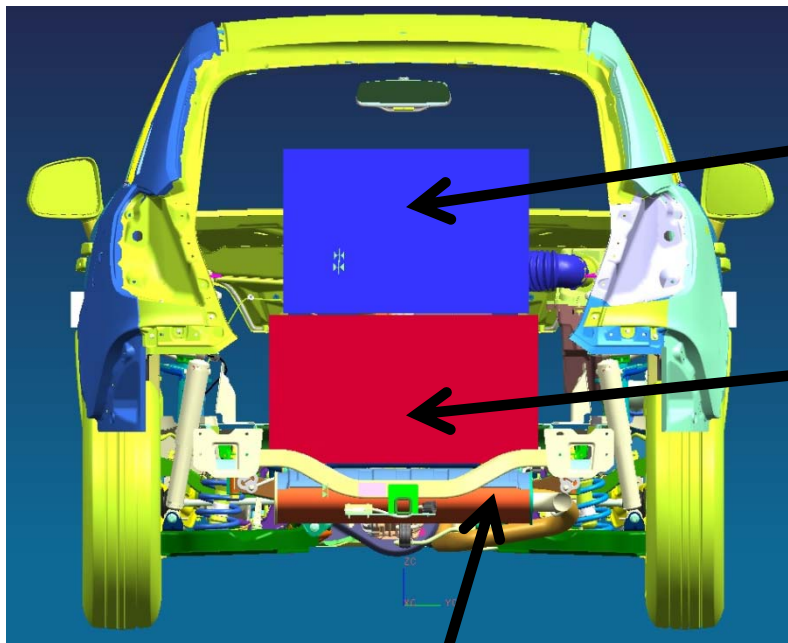

Cargo Envelope (for Emissions measurement equipment)

Battery Envelope
.2205 m³ for 20 kWh

Stock VUE muffler location

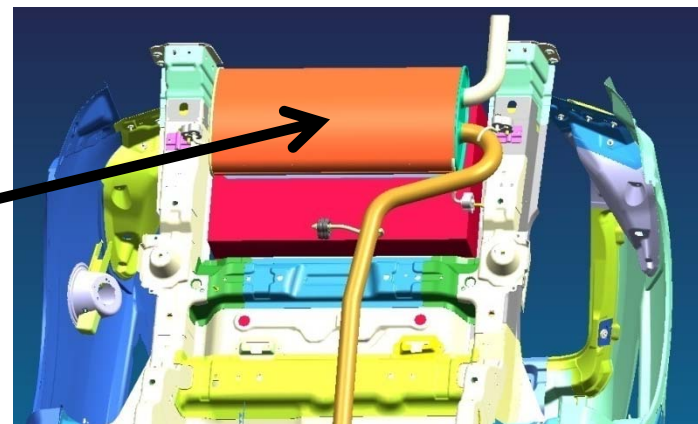

EcoCAR HEV Design and Analysis

Electric Rear Wheel Drive Gearbox

Adam Binley, Jake Soepber, Kyle McWilliam, Bryce Donnelly, Yoshua Ichihashi & Sean Walsh

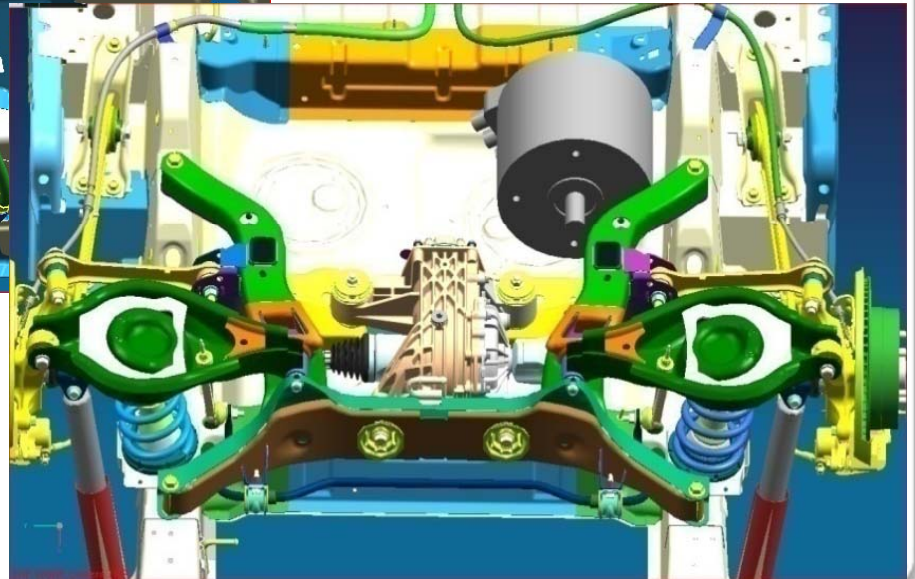
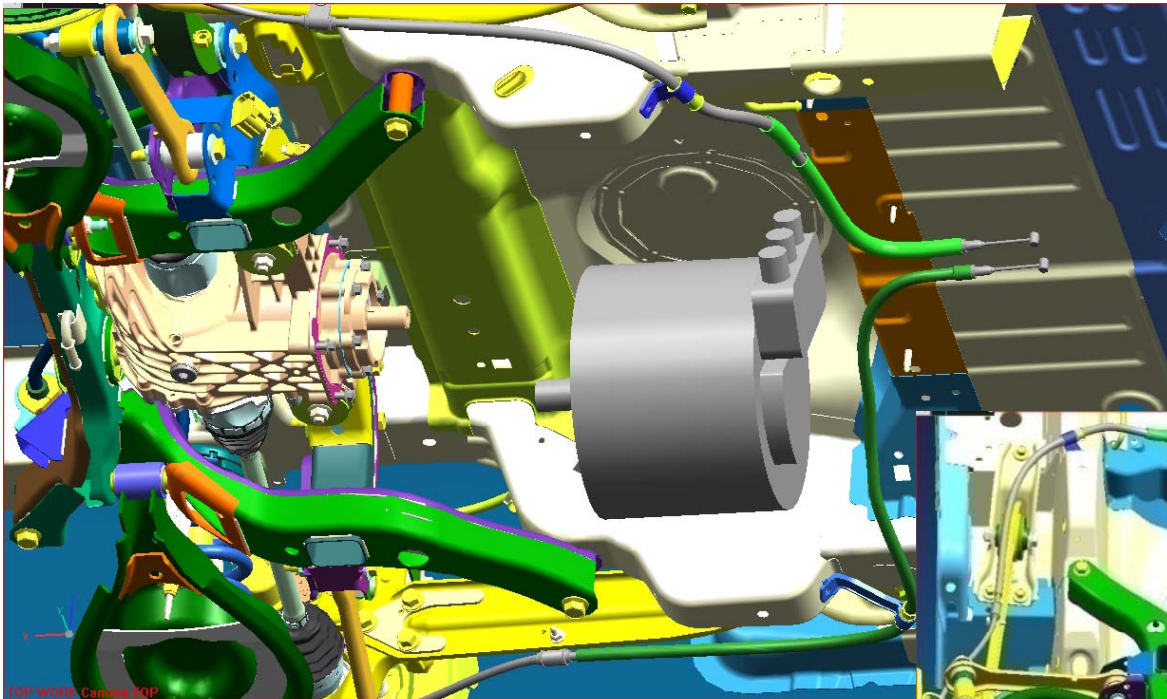

EcoCAR HEV Design and Analysis Using Unigraphics NX

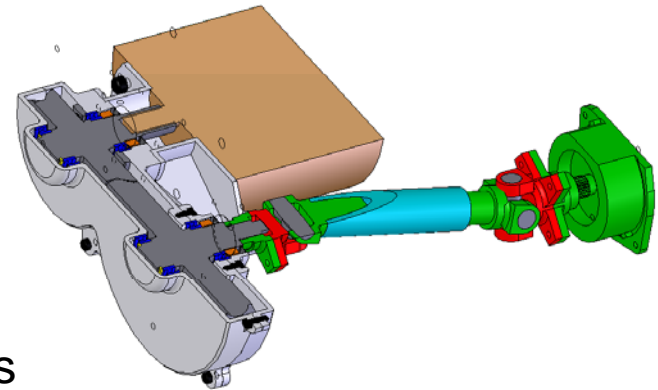
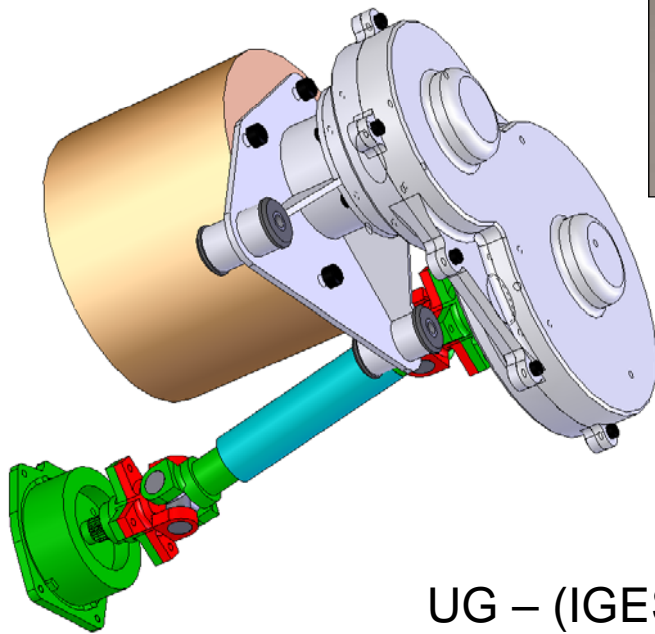
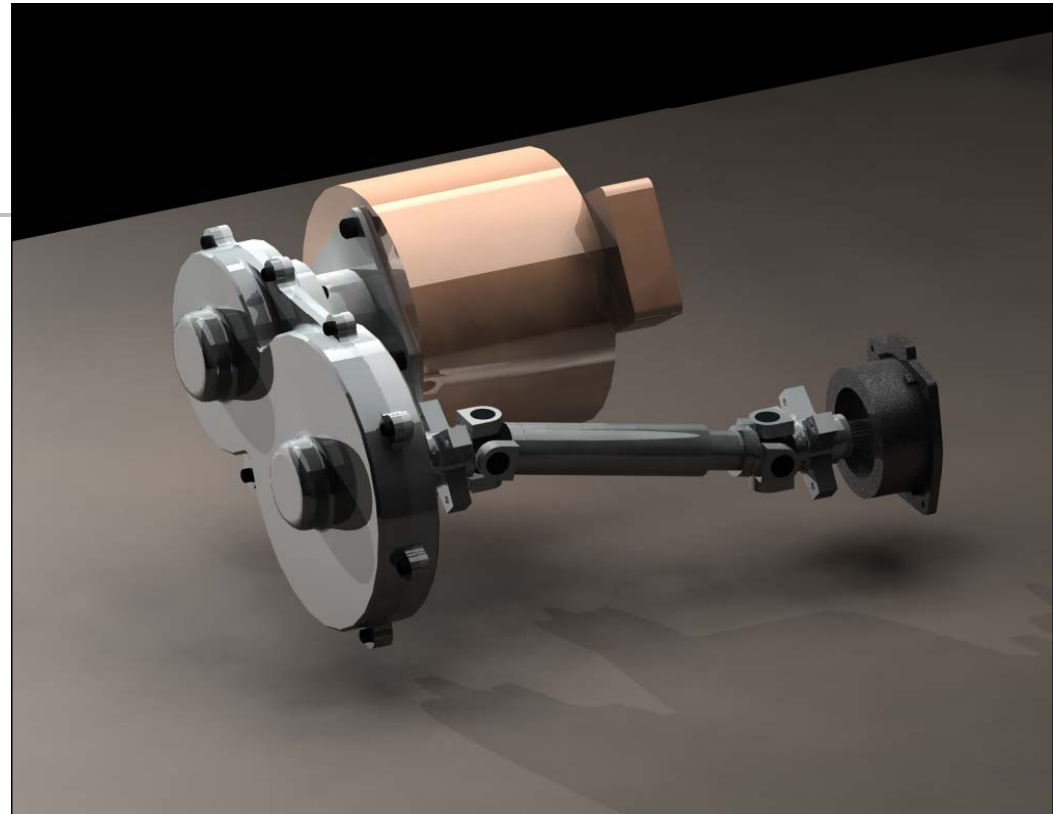

UG – (IGES) - SolidWorks

Plug-In 2-Mode Plus AWD E-REV

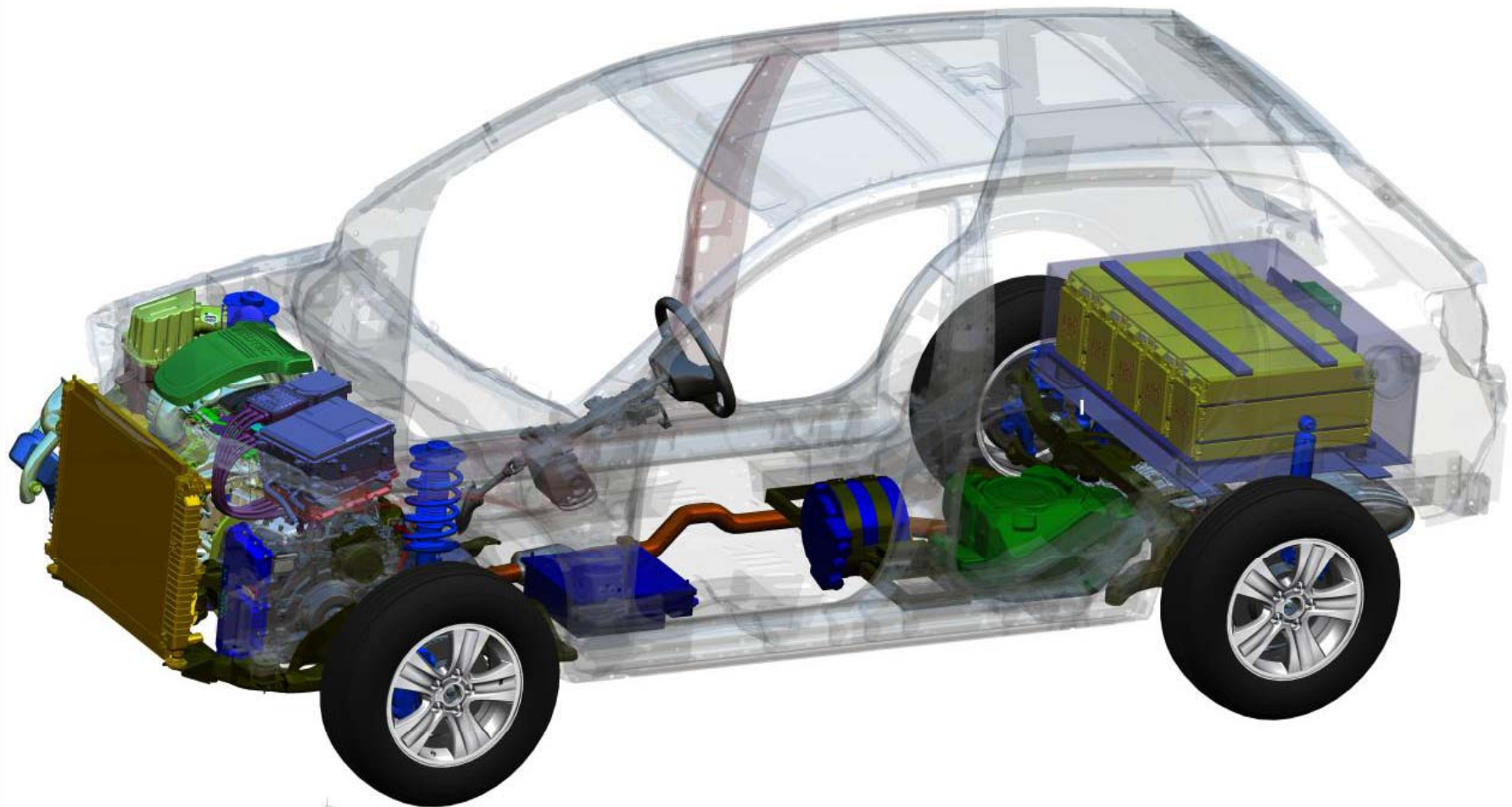

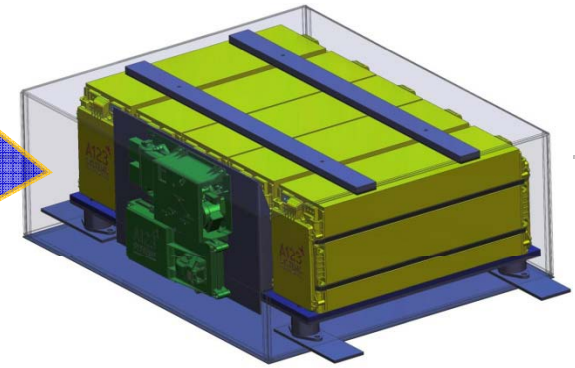
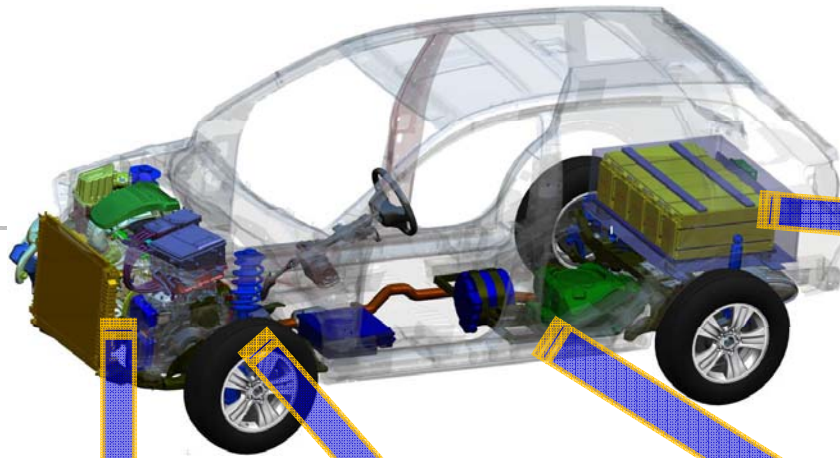

**A123 21kW-hr
HV Battery Pack**

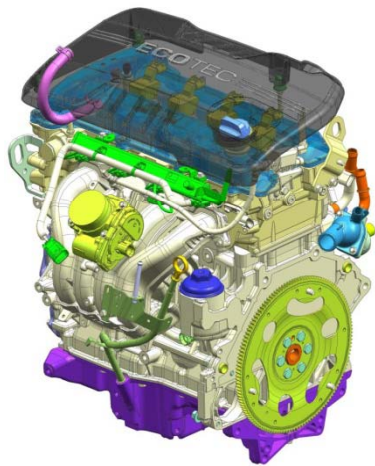

**GM 2.4 L EcoTec
E85 Fuel**

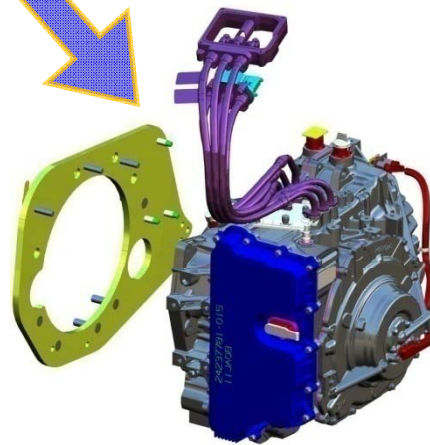

**GM 2-Mode FWD
Transmission**

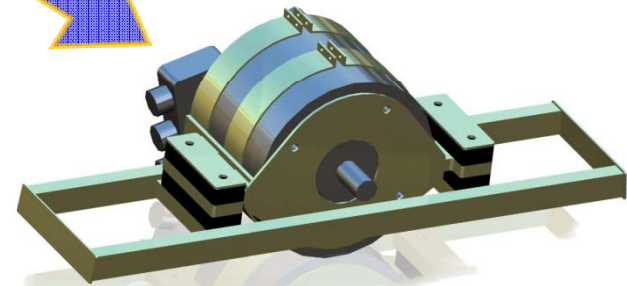

**UQM PowerPhase
125kW
Rear Traction Motor**

Key UGS NX Tutorials

- **Course Webpage:**
 - [Unigraphics NX Tutorials and Related Documents](#)
- **NX CAST 6 - A Comprehensive NX CAST 6 Tutorial**
 - Available on the PCs with UGS NX 6
 - CD of NX CAST 6 Available
- **NX5 for Engineering Design - A Complete Tutorial**
(M. C. Leu and A. Joshi, Missouri Univ of Sci. & Tech.)
 - Introduction
 - Getting Started
 - Form Features
 - Feature Operations
 - Drafting
 - Sketching
 - Freeform Feature
 - Assembly Modeling
 - Manufacturing
 - Finite Element Analysis
- **Unigraphics NX 6.0 Tutorial Update** (Daniel Prescott)
- **Unigraphics NX 6 Tips & Recommended EcoCAR CAD Procedures** (D. Prescott)

UGS NX 6 Reference

- **Parametric Modeling with UGS NX 6 Book** (by Randy H. Shih, from SDC)
 - [Table of Contents](#)
 - Sample [Chapter 2 - Parametric Modeling Fundamentals](#)
- [NX6 Modeling Tutorial](#) by John K. Layer (2008-8-26)
- [Explanation of Buttons Used for Sketching in Unigraphics](#)
- [UGS NX Drafting Tutorial](#) (Michigan Tech Univ)
- [NX Advanced FEM](#) (Version NX 5) (Siemens)
- [Team center Visualization Concept Desktop Hands-on Tutorial](#) (UGS)
- [UGS Open and API Programming](#)
- [NX5 Review Article](#): Jeffrey Rowe, "CAD/CAM/CAE solution from Siemens PLM Software is primed for production," *Cadalyst*, Nov 1, 2007
- GM X Challenge UG Discussion (R. Salmon, GM Vehicle Modeling, Available to EcoCAR Members Controlled Page)

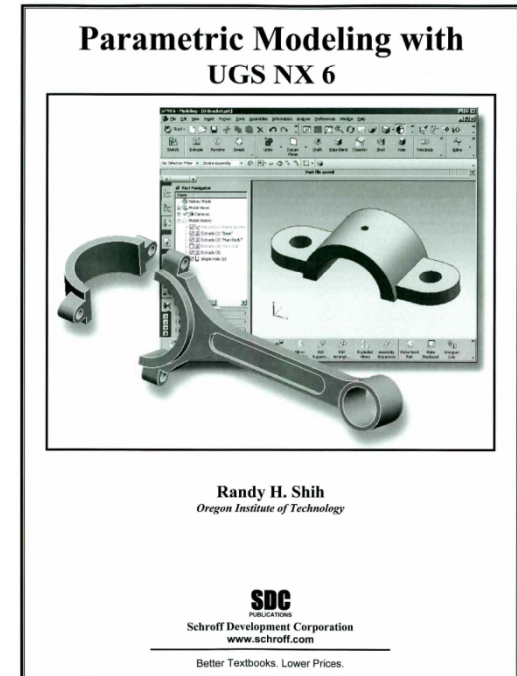

Start UGS NX6

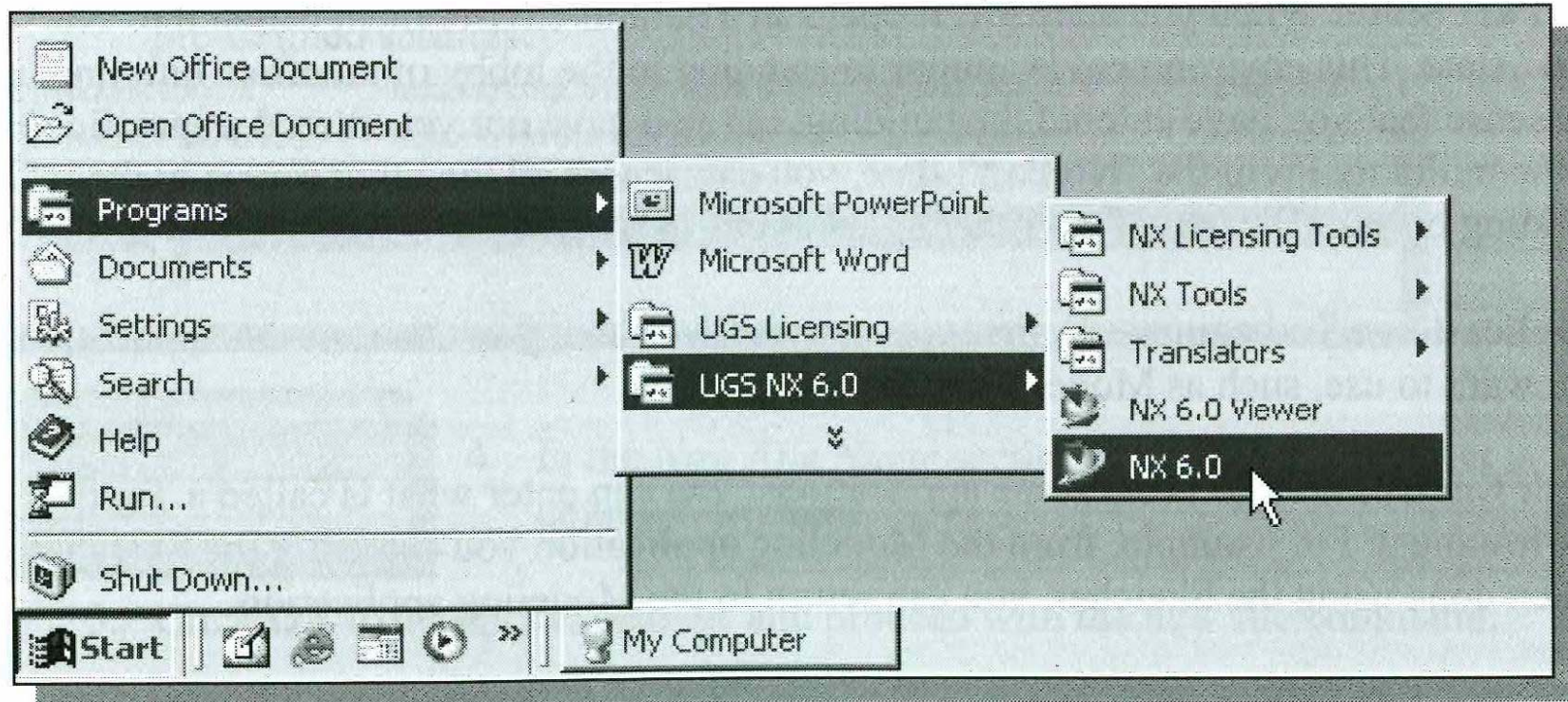

UGS NX6 Screen

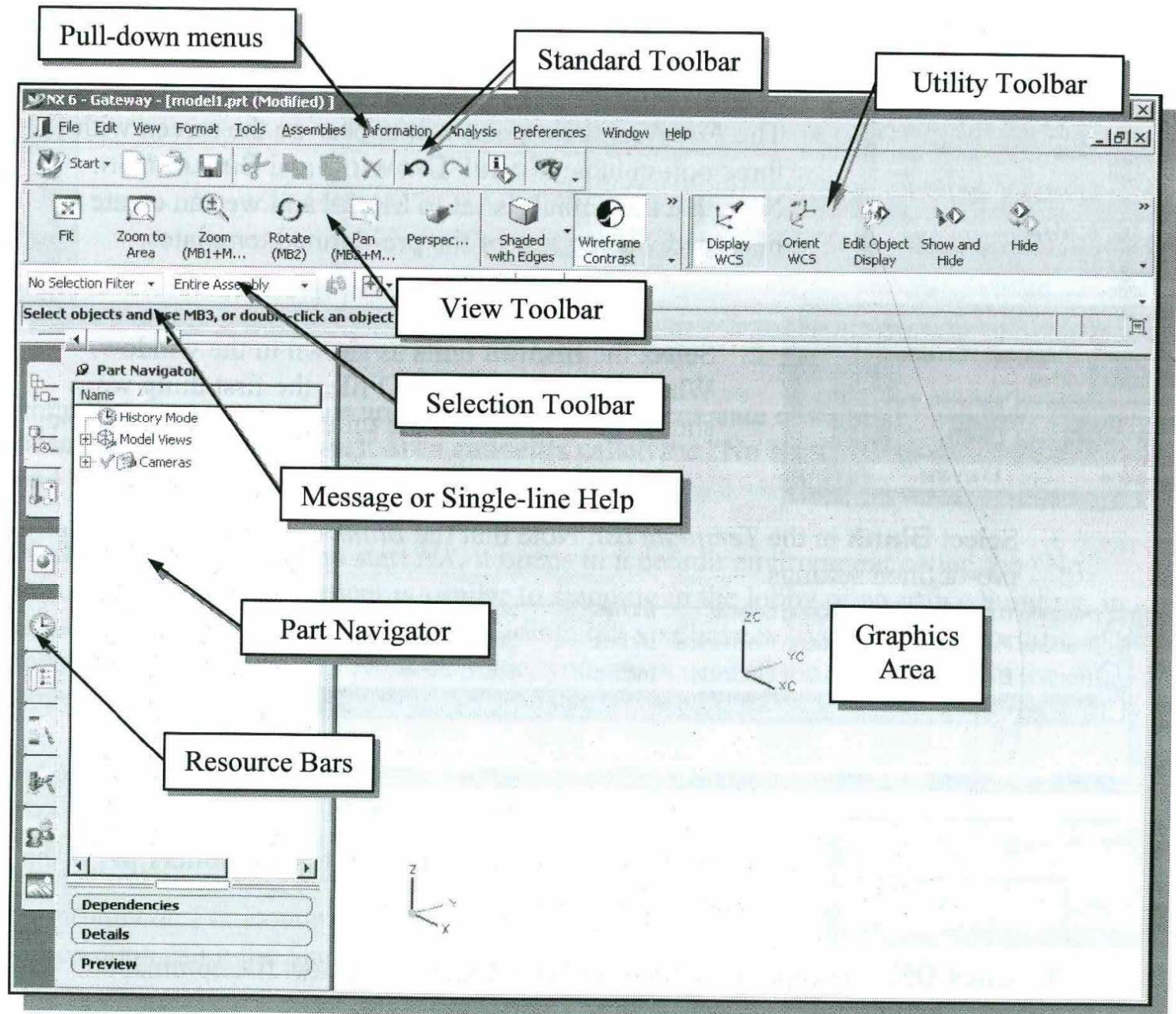

Application Screen

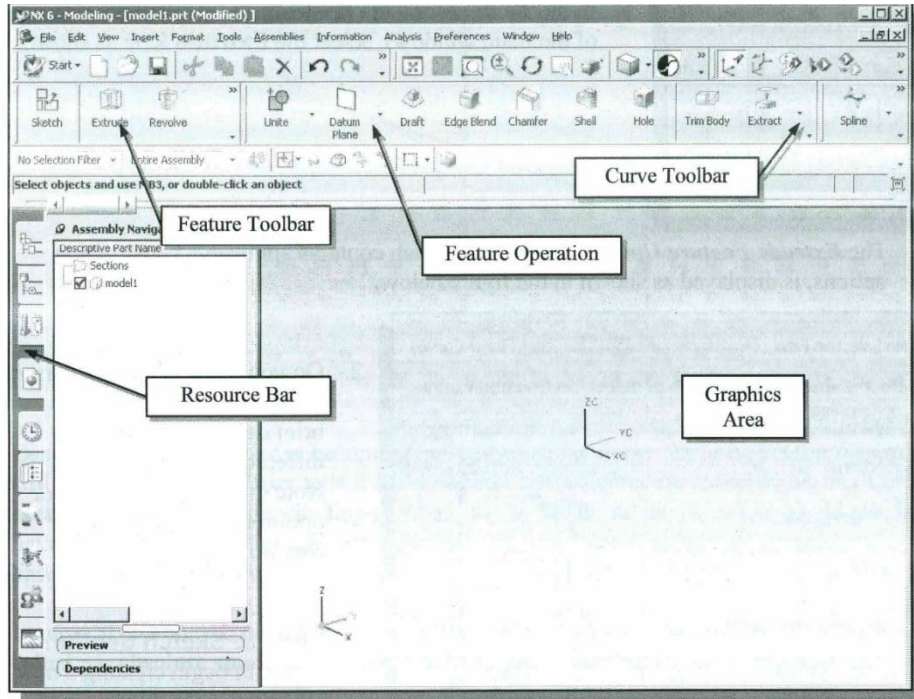

Form Feature Toolbar

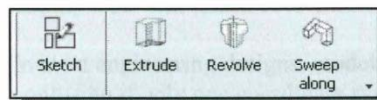

This toolbar contains tools that allow us to quickly create 2D sketches and form 3D features.

Feature Operation Toolbar

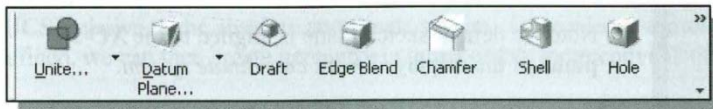

This toolbar contains tools that allow us to quickly create placed features.

Curve Toolbar

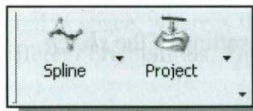

This toolbar contains tools that allow us to quickly access 2D curve options.

- For the *Adjuster* design, we will create an extruded solid as the first feature.

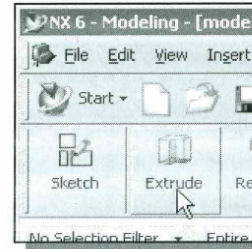

1. In the **Feature** toolbars (toolbars aligned to the right edge of the main window), select the **Extrude** icon as shown.

- The **Extrude Feature Options dialog box**, which contains applicable construction options, is displayed as shown in the figure below.

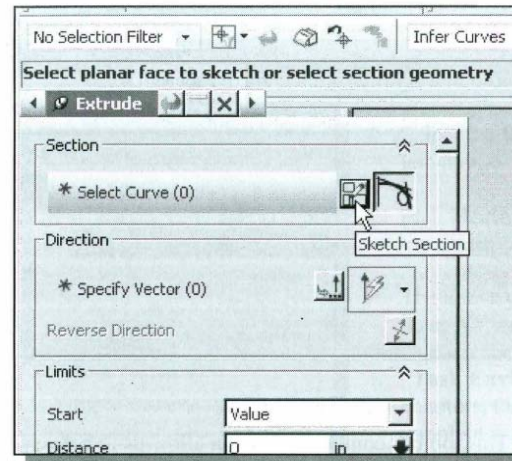

2. On your own, move the cursor over the icons and read the brief descriptions of the different options available. Note that the default *Extrude* option is set to **Select Section**.
3. Click the **Sketch Section** button to begin creating a new 2D sketch.

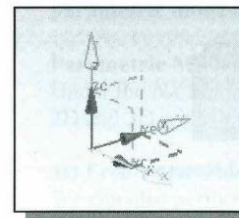

- ❖ Note the default sketch plane is aligned to the **XC-YC plane** of the displayed *work coordinate system*.

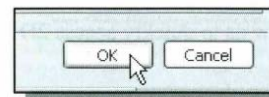

4. Click **OK** to accept the default setting of the *sketch plane*.

- **Pull-down Menus**

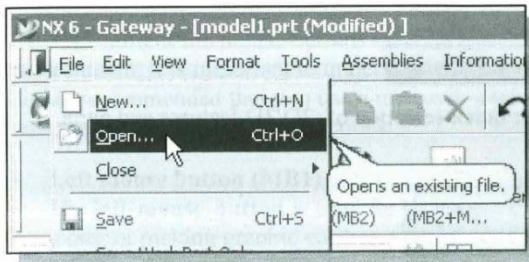

The *pull-down* menus at the top of the main window contain operations that you can use for all modes of the system.

- **Standard Toolbar**



The *Standard* toolbar at the top of the screen window allows us quick access to frequently used commands. For example, the file-related commands, such as Switching Applications, New Part, and Save.

- **View Toolbar**

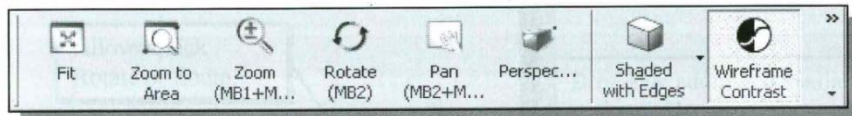

The *View* toolbar allows us quick access to frequently used view-related commands, such as Zoom, Rotate, Creating Section View and Shaded Solids.

- **Utility Toolbar**

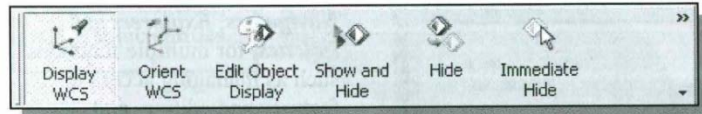

The *Utility* toolbar allows us quick access to *WCS manipulation*, such as WCS display, Move WCS, and control of the *Object display options*.

- **Additional Tools**

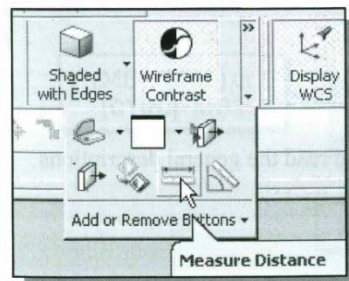

The double-arrow at the end of each toolbar can be used to access the additional tools that are available.

- **Selection Toolbar**

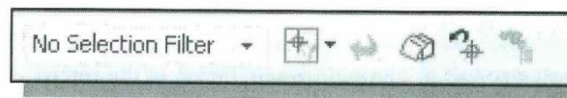

The *Selection* toolbar provides tools for quick selection of 2D/3D features and parts.

- **Message and Status Bar**

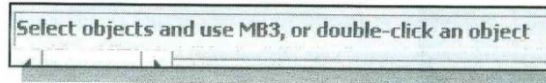

The *Message and Status Bar* area shows a single-line help when the cursor is on top of an icon. This area also displays information pertinent to the active operation.

- **Part Navigator**

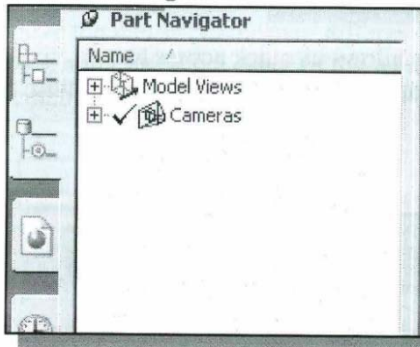

The *Part Navigator* area shows information regarding the current active model. This area is used by the *Resource Bars* options described below.

- **Resource Bars**

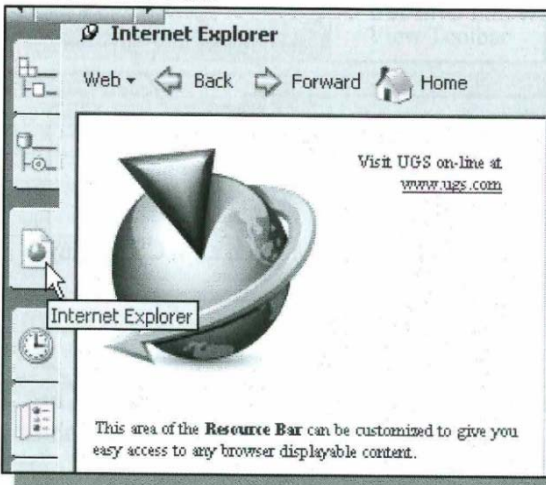

➤ The *Resource Bars* provide three groups of resources, **Navigators**, **Explorers** and **Palettes**, for multiple functions such as managing access to features and editing, and providing alternate access to functions in the *Context* menu.

This area of the **Resource Bar** can be customized to give you easy access to any browser displayable content.

Use of Mouse Buttons

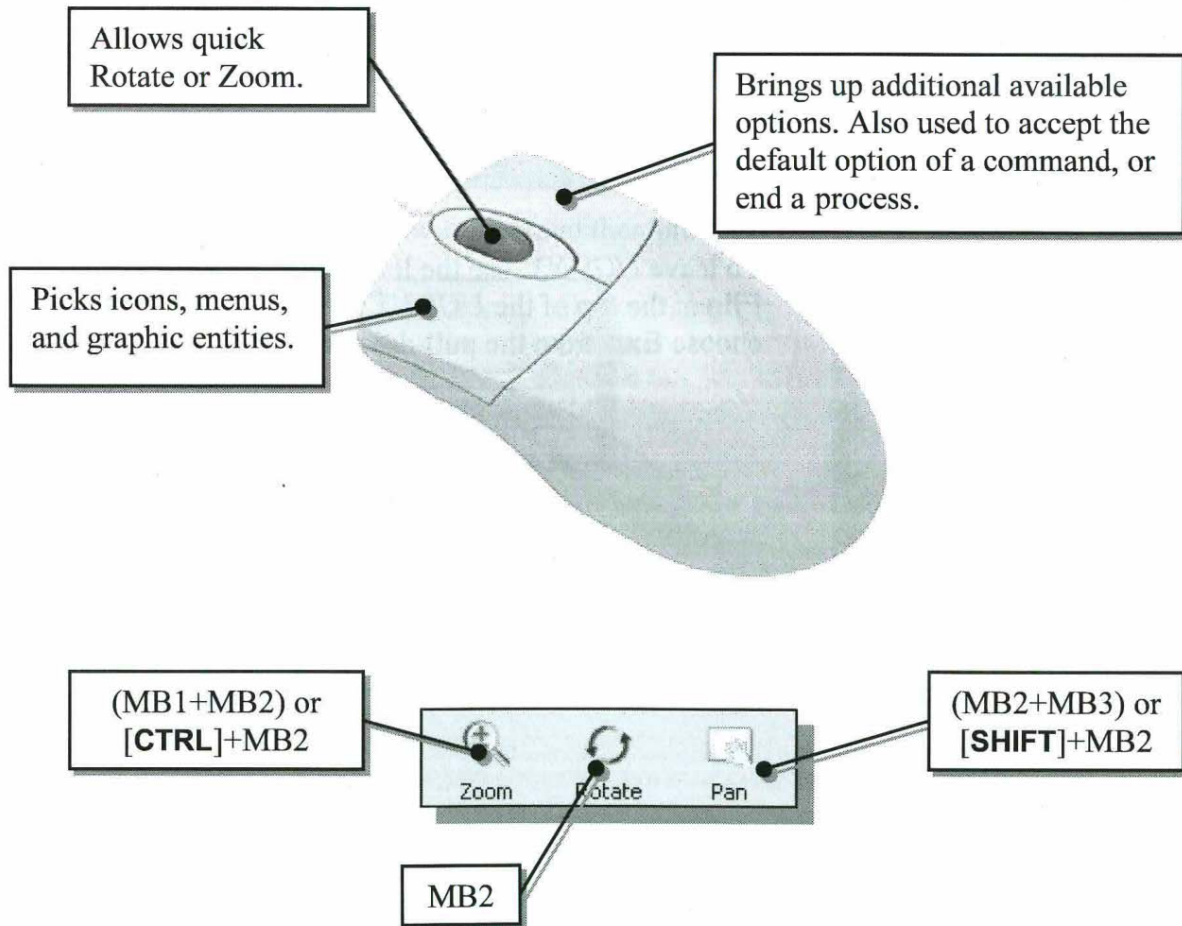

Sketching, Dimensioning and Modeling

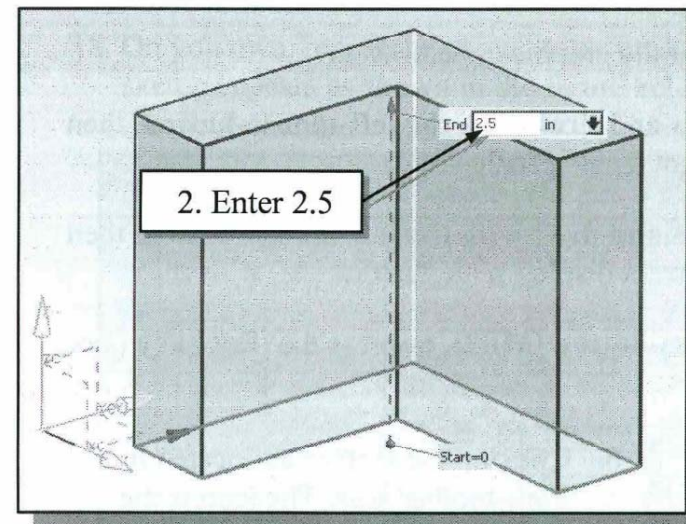
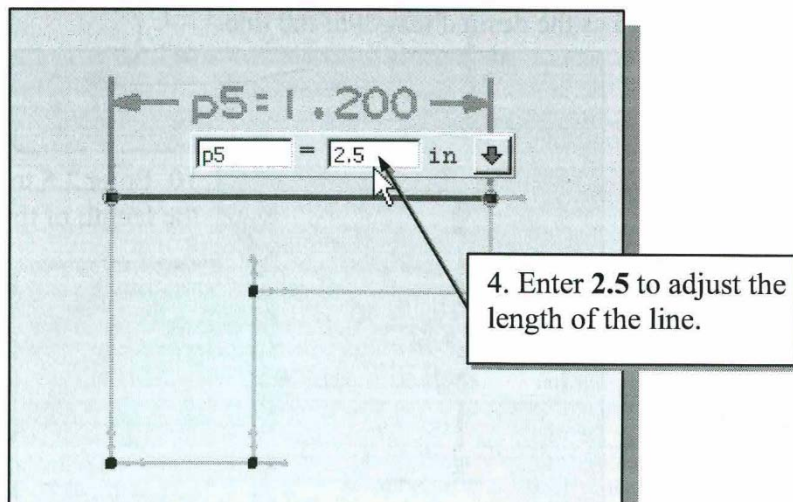
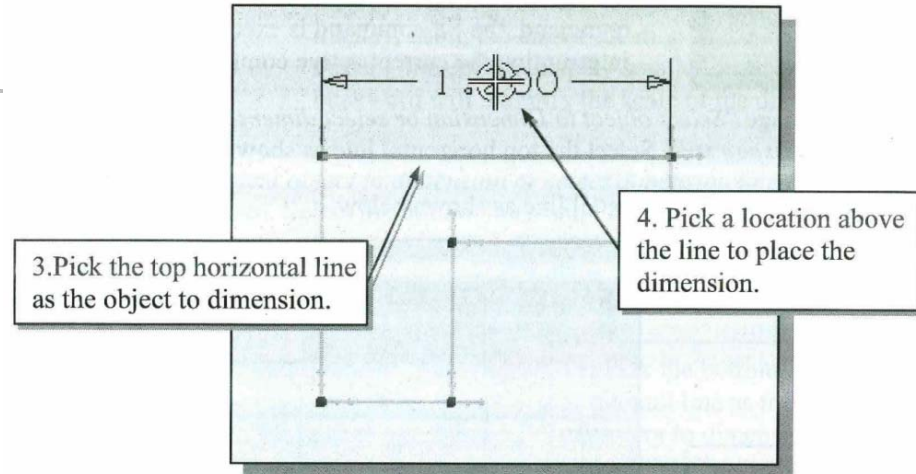
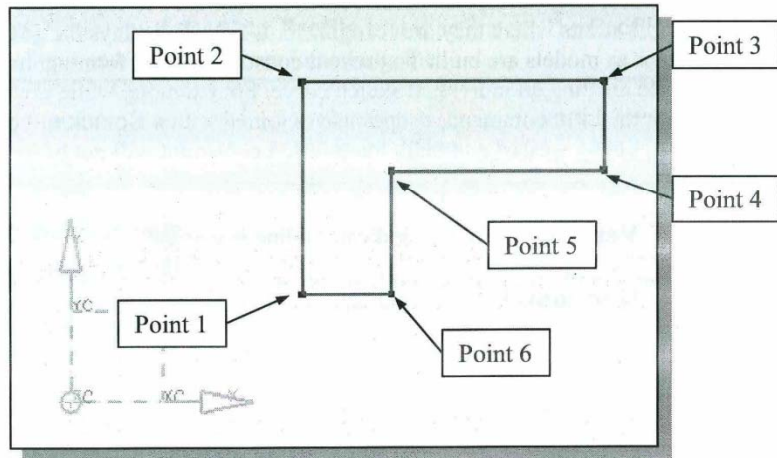

Different Display Orientations

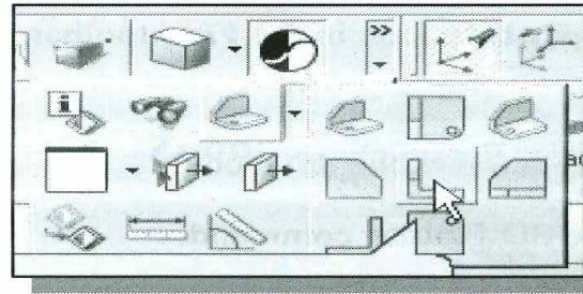

1. Select **Fr** to change the display orientation. Press **[Ctrl+Alt+Command]**.

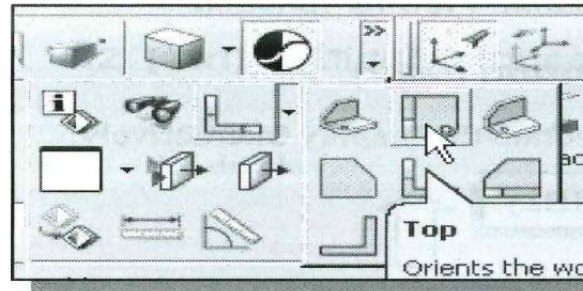

2. Select **To** to change the display orientation. Press **[Ctrl+Alt+Command]** to activate this command.

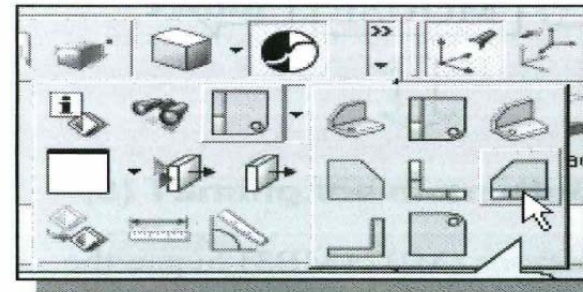

3. Select **Ri** to change the display orientation. Press **[Ctrl+Alt+Command]** to activate this command.

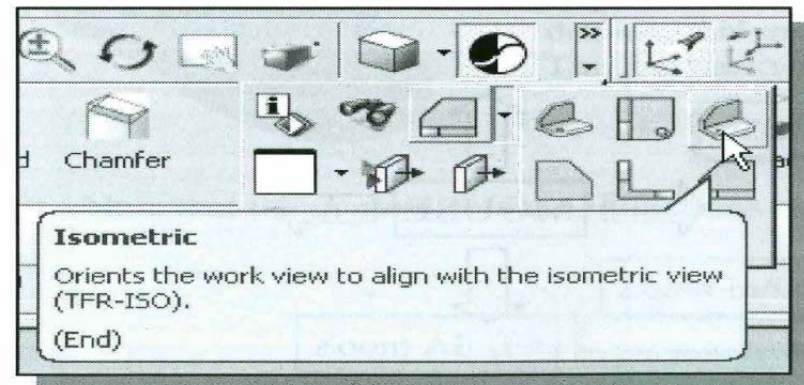

CSG Tree

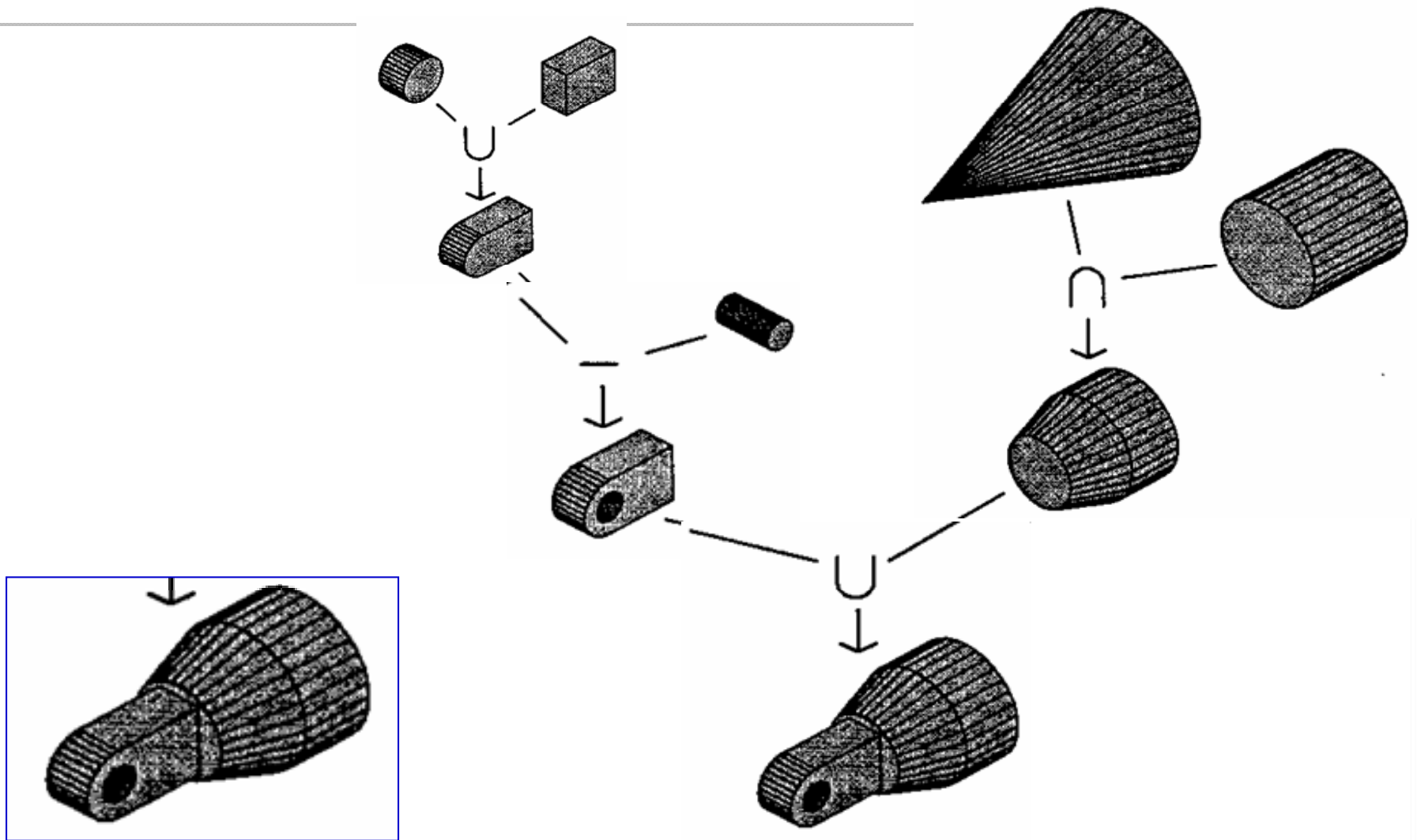

CSG Modeling and Parent-Child Relations

Modeling Strategy - CSG Binary Tree

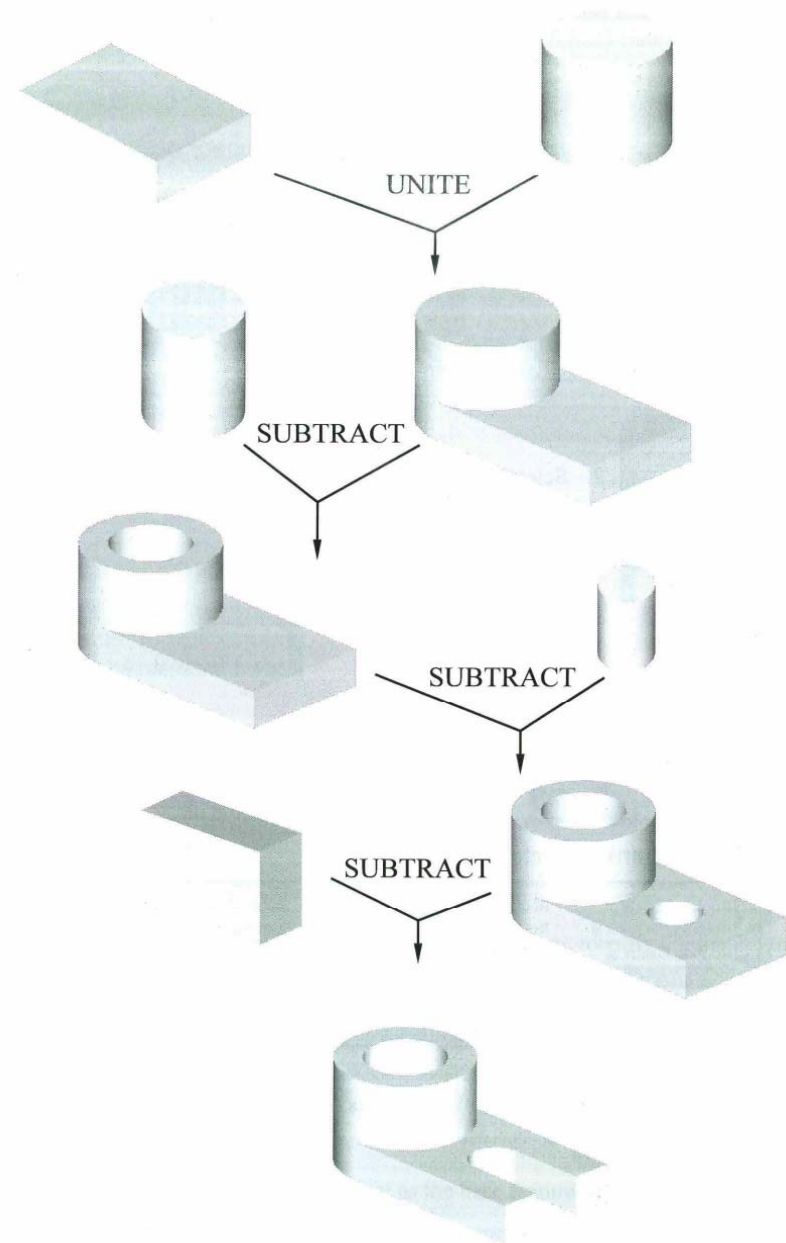
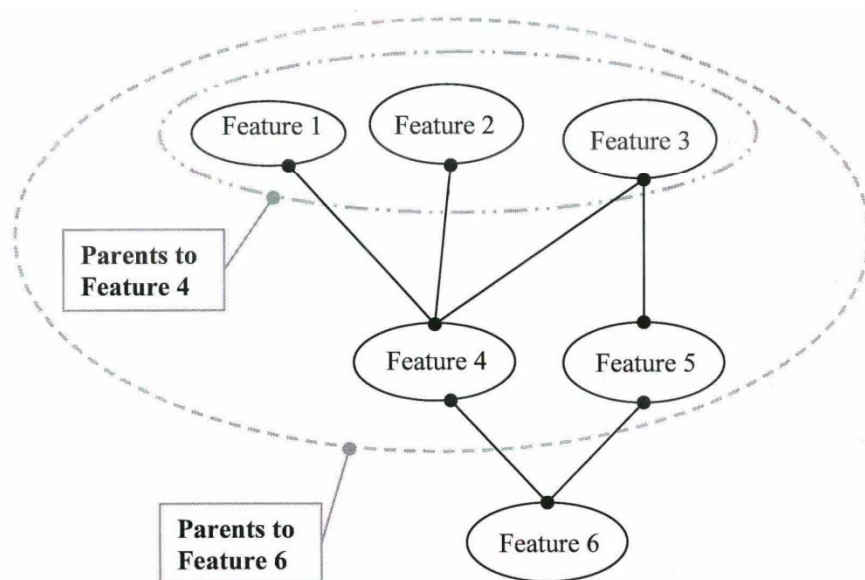

Drawing Generation

UGS NX Drafting Mode



1. Click on the **Start** icon in the toolbar to display the available options.
 2. Select **Drafting** from the options.
- ❖ In the *Sheet* dialog box, *UGS NX* settings for the drawing sheet

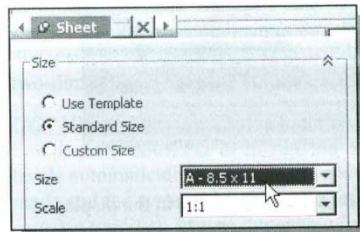

3. Select **A-8.5x11** from the size options.
4. Confirm the **Scale** is **full scale**.

➤ Note that *Sheet 1* is the sheet name that is displayed in the sheet name area.

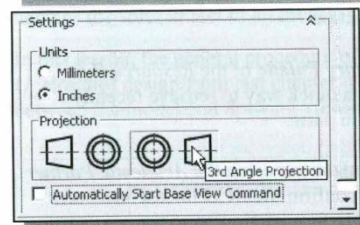

5. In the *Settings* area, set to **Inches** and then to **3rd Angle Projection**.
6. **Uncheck** the **Automatically Start Base View Command** option.

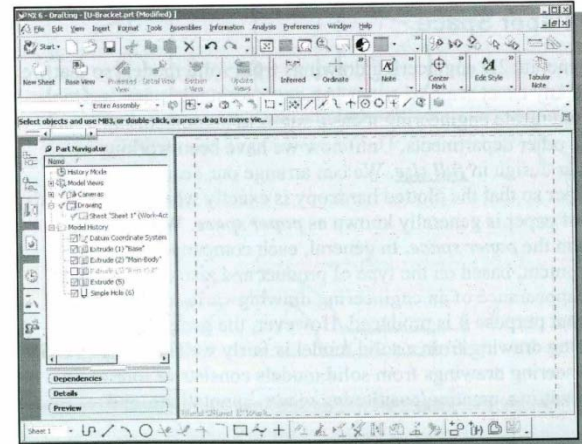

Adding a Base View

❖ In *UGS NX Drafting* mode, the first drawing view is the primary view in a drawing; other views are created as *base views*. *UGS NX* will try to create all views to be shown. By default, *UGS NX* will try to create a *base view* of the solid model.

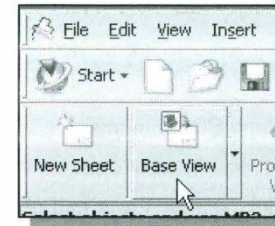

1. Click on the **Base View** toolbar icon to create a base view.

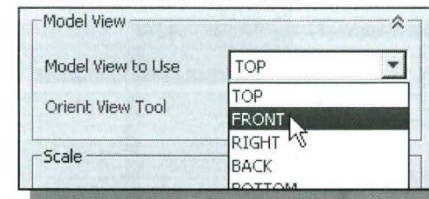

2. In the *Model View* dialog box, select **FRONT** as the view orientation.

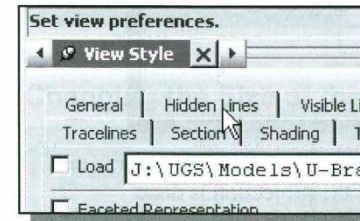
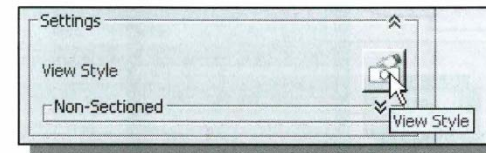

4. In the *View Style* dialog box, set the **Hidden Lines** to **Invisible**.
- The *View Style* settings for the drawing view.

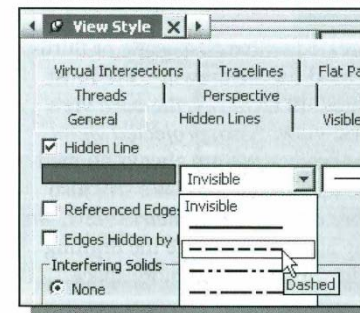

5. Choose **D** hidden line style.

Modeling – Extrusion and Revolving

Modeling Strategy

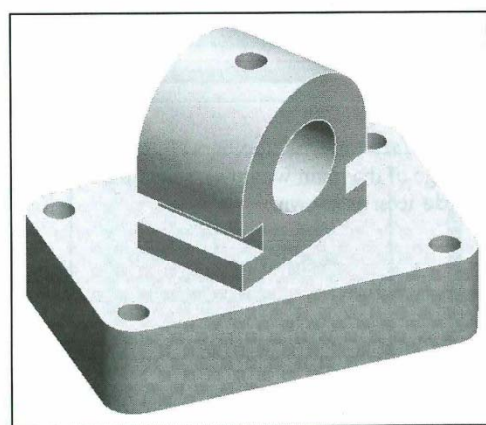
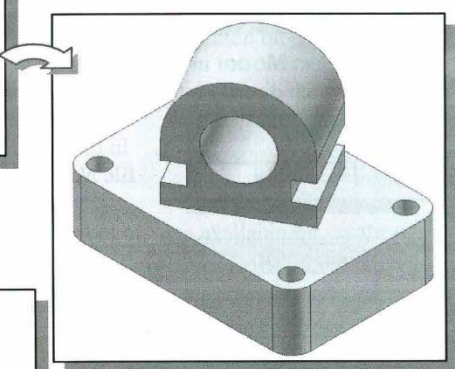
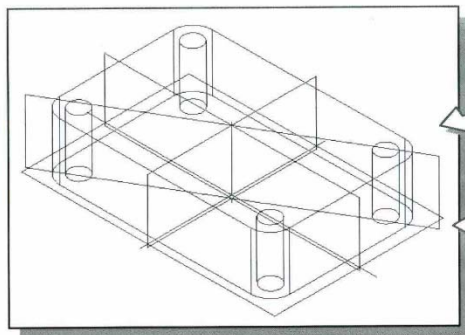
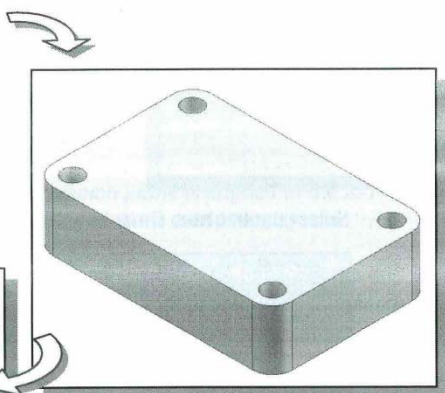
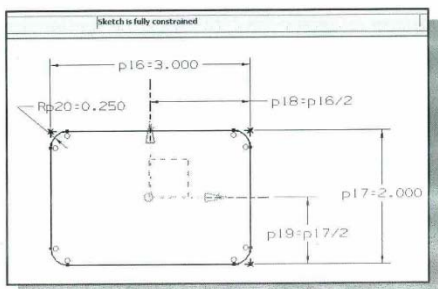

Modeling Strategy – A Revolved Design

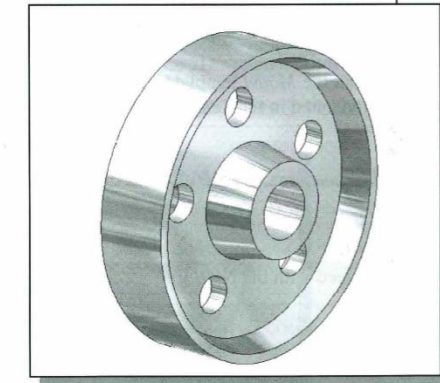
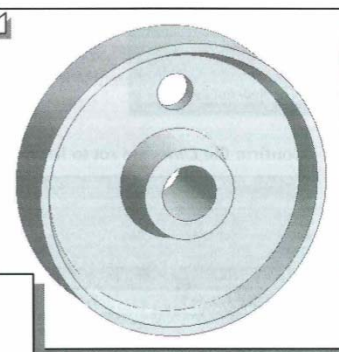
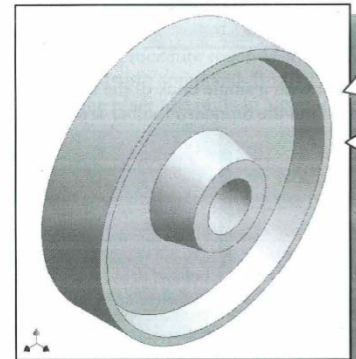
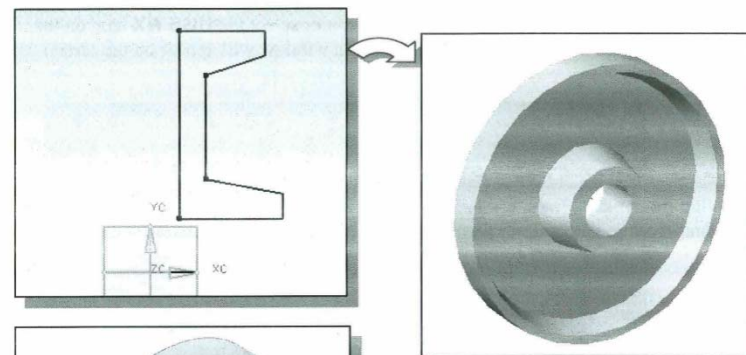

Modeling Strategy

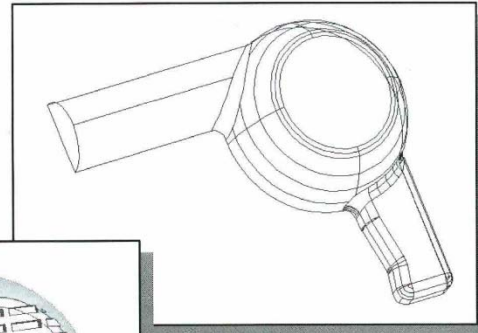
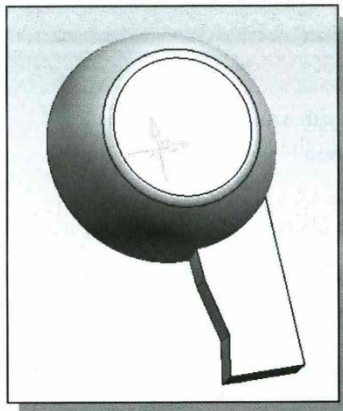
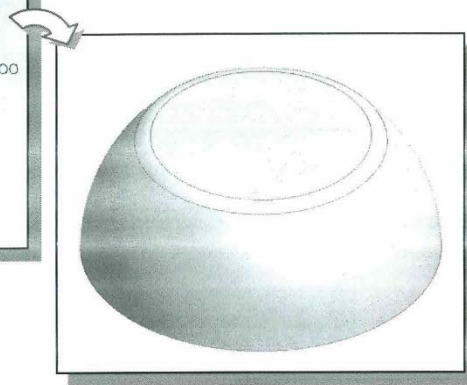
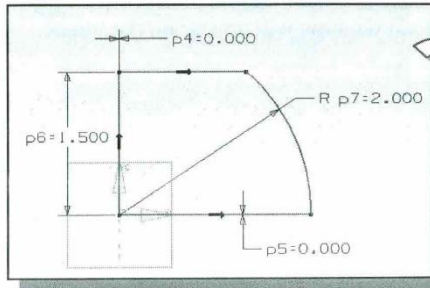

**Advanced
Modeling**

Assembly Relations

- **Touch (Mate)** – Constraint positions components face-to-face, or adjacent to one another, with faces flush. Removes one degree of linear translation and two degrees of angular rotation between planar surfaces. Selected surfaces point in opposite directions. The Touch constraint positions selected faces normal to one another, with faces coincident.

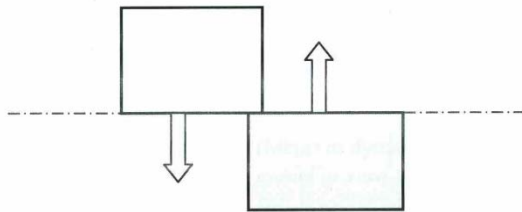

- **Align** – Makes two planes coplanar with their faces aligned in the same direction. Selected surfaces point in the same direction. The Align constraint aligns components adjacent to one another with faces aligned. For axisymmetric objects, Align can be used to align two circles or cylindrical surfaces, including their center axes and planes. Selected circular surfaces can become co-axial or tangent to each other.

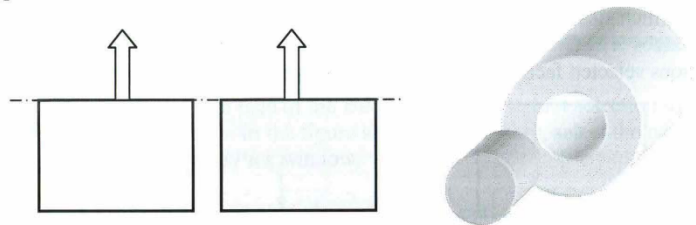

- **Angle** – Creates an angular assembly constraint between parts, subassemblies, or assemblies. Selected surfaces point in the direction specified by the angle.

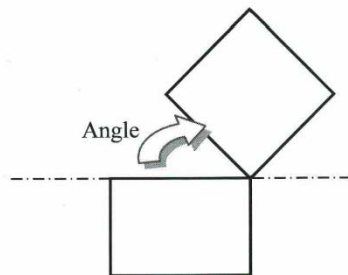

- **Parallel** – Constrains the surfaces or direction vectors of two selected objects as parallel to each other.

- **Perpendicular** – Constrains the surfaces or direction vectors of two objects as perpendicular to each other.

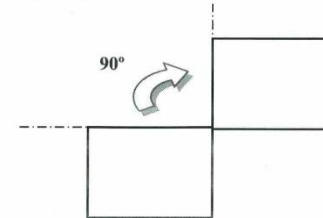

- **Concentric** – Lets you center one object to the center of the other of object.
- **Center** – Lets you center one object anywhere along the center of another object, or center one or two objects between a pair of objects.
- **Distance** – Constraint positions components face-to-face, and can be offset by a specified distance. Specifies the minimum 3D distance between two objects. You can control on which side of the surface the solution should be by using positive or negative values. The Distance constraint is similar to the Touch constraint, which also positions selected faces normal to one another, with faces coincident.

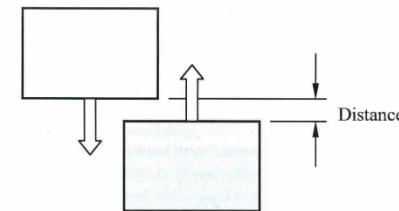

- **Align/Tangent** – Aligns selected faces, planes, cylinders, spheres, and cones to contact at the point of tangency. Tangency may be on the inside or outside of a curve, depending on the selection of the direction of the surface normal. A Tangent constraint removes one degree of translational freedom.

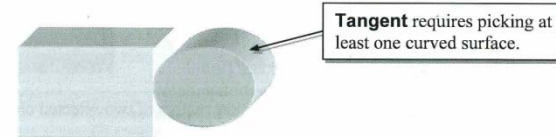

Assembly and Exploded View

The *Shaft-Support Assembly*

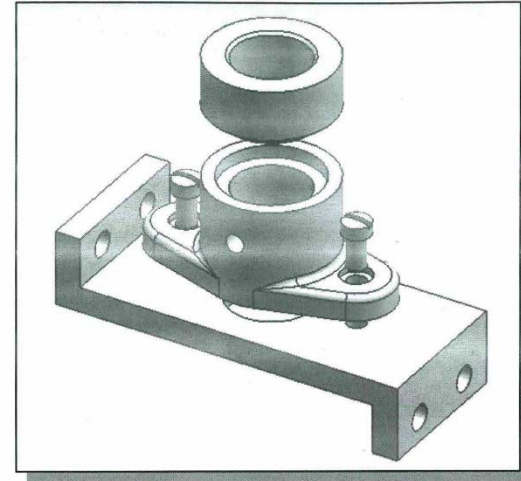
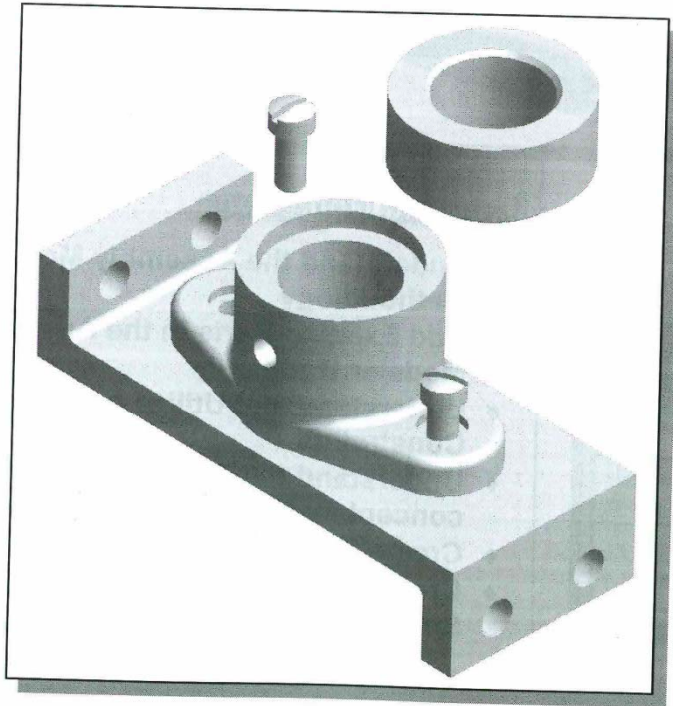

Switching the Exploded/Unexploded Views

- *UGS NX* allows us to store as many exploded views as desired and we can also switch to any of the exploded views by choosing the one from the *Exploded Views* list box.

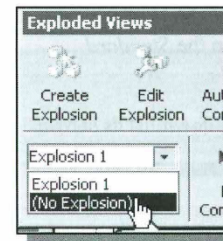

1. Inside the *Exploded Views* dialog box, select **(No Explosion)** to switch to the unexploded view of the assembly model.

